

LOCTITE*Adhesives for more
reliable assemblies***APPLICATION CASE HISTORY****No. 223**

PST® Pipe Sealants Help Motion Industries Install Leak-Free Hydraulic Systems

Situation:

Motion Industries' Service Department of Nashville, TN is contracted by industrial customers to install, repair or modify hydraulic power systems.

Terry Jones and Joey Musice, field technicians for Motion Industries, had been contracted to install a new hydraulic system at a large industrial assembly plant. This system included over 100 feet of piping and over 300 hydraulic couplings, adaptors and fittings. Since this was being done at the customer's location, they knew they needed a sealant that would seal instantly and remain reliable for several years.

Solution:

These two field technicians keep their truck well-stocked with Loctite® PST® 567 and Loctite® 545 Pneumatic/Hydraulic Pipe Sealants, and Primer N 7649.

PST 567 seals stainless steel fittings and galvanized and other inert metals. It is excellent for high pressure (up to 10,000 psi on 1/2" NPT fittings) and prevents galling of stainless steel during assembly. PST 567 is Teflon® filled for fast fitting assembly and withstands continuous temperatures to 400°F.

Loctite 545 Pneumatic/Hydraulic Sealant is non-contaminating (without Teflon®) for locking and sealing high pressure fluid power systems. It cures on as-received fittings and withstands temperatures to 300°F.

Both pipe sealants seal instantly up to 1000 psi, can be applied manually or with automated equipment and allow for easy disassembly with hand tools.

Prior to assembly, Joey and Terry primed each female fitting with Primer N and applied PST 567 to the male fitting. 95% of the threads were fine, very fine or coarse and had PST 567 applied. Only a few JIC fittings needed 545 Pneumatic/Hydraulic applied to them.

Results:

Once the job was completed, they filled and primed the system with hydraulic oil. Then the system was immediately brought up to operating pressure, and there was zero leaks. The customer was amazed, as his own maintenance team was constantly fighting leaks on other systems.

Joey and Terry revealed their leakproof secret of Loctite PST 567, Loctite 545 and Primer N. "We rely heavily on products that work," said Joey. "And we know we can depend on these Loctite products to help us get the job done right." Terry agreed, "We're only as good as the leaks that don't show up. With Loctite, we're great!"

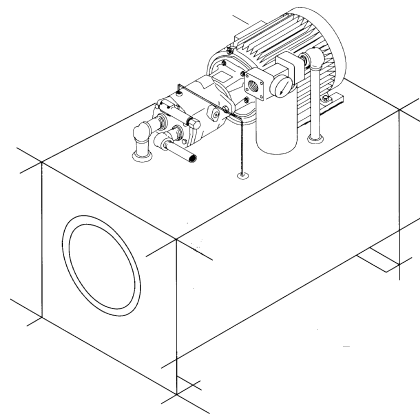

Typical hydraulic system installed and serviced by Motion Industries.

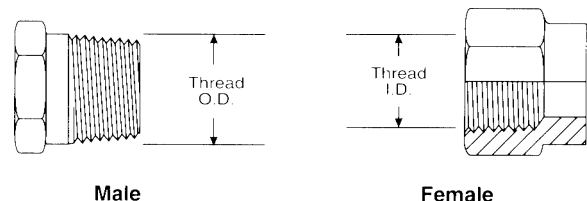

Male

Female

The female fitting is primed with Primer N, and PST 567 pipe sealant is applied to the male fitting for a leakproof installation.

Loctite Americas

U.S.A.
Loctite Corporation
1001 Trout Brook Crossing
Rocky Hill, Connecticut 06067
860-571-5100
Telefax: 860-571-5465

CANADA
Loctite Canada Inc.
2225 Meadowpine Blvd.
Mississauga, Ontario L5N 7P2
800-263-5043 (within Canada)
905-814-6511
Telefax: 905-814-5391

MEXICO
Loctite Company de México, S.A. de C.V.
Calzada de la Viga s/n, Fracc. Los Laureles
Loc. Tulpetlac, C.P. 55090
Ecatepec de Morelos, Edo. de México.
01-800-8499-412
Telefax: 011-525-787-9404